



***Mounting set for installation
rack with brackets for tiled roof***



Mounting set for installation rack with brackets for tiled roof

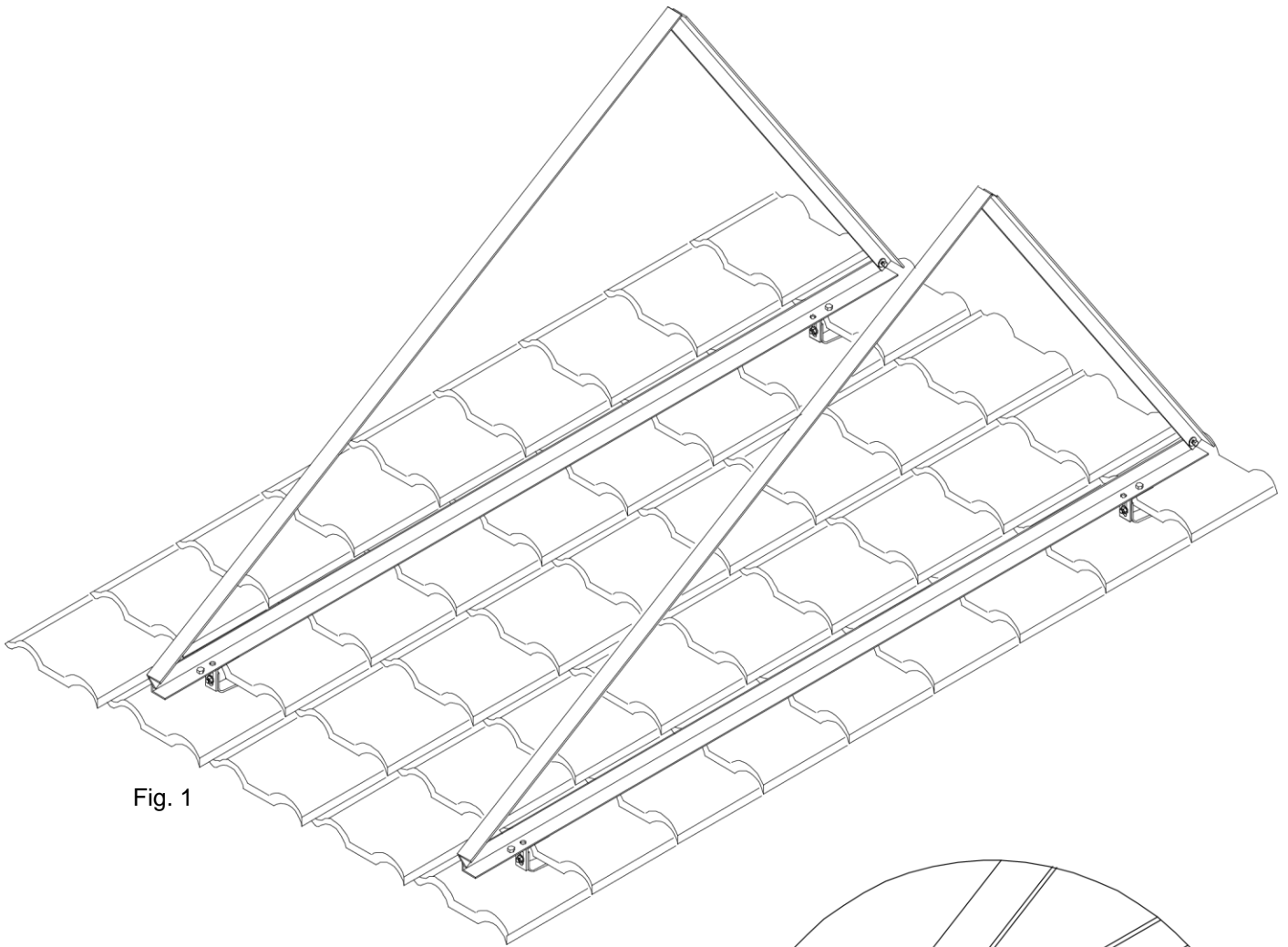

Fig. 1

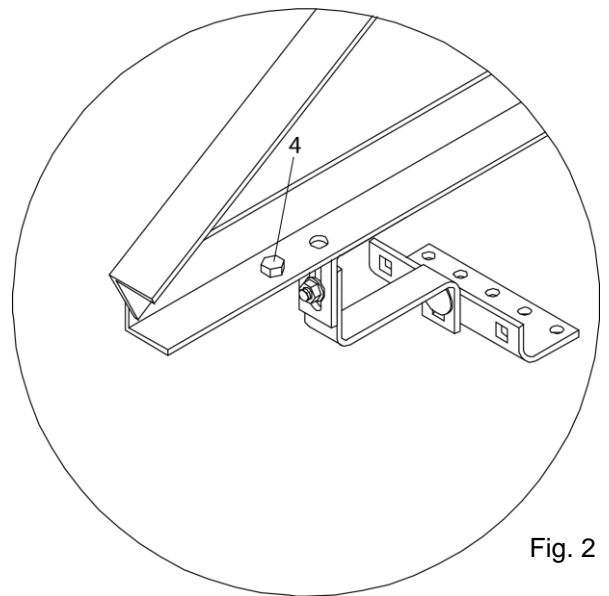

Fig. 2

Pos.	Code	Description	Quantity per set
1	1000192038	Adjustable roof hook (incl. carriage-bolts and nuts)	2
2	29300	Frame screw TG 8,0 x 100 mm	6
3	29111	Carriage-bolt M8 x 25 mm_V2A	2
4	1000192047	Nut with flange M8_V2A	2



Mounting set for installation rack with brackets for tiled roof

1. Determine the position of the panels on the roof. Remove for each hook (1) a roof tile which is located exactly on the rafter behind. Consider that the upper roof hooks have to be mounted two tile rows below the roof ridge!
2. The three press cuts on the base line of the roof hook (1) can compensate the lateral transfer (Fig. 3).
3. The hooks (1) can be adjusted to the height of the roof battens and/or tiles with the two square neck carriage-bolts. The distance between the panels and the roof should be kept as small as possible. The hooks are fixed with panels screws (2) to the rafter (Fig. 4).
4. The installation racks (accessories, order separately) are fixed with carriage-bolts M8 (3) and nuts (4) at the front and backside of the basic profile to the roof hooks (1) (Fig. 5 and 6).
The drillings of the basic profile with $\varnothing 9$ mm must be drilled on site – depending on the distance between the upper and the lower roof hooks (1).
5. Finally check that all screws (2, 3) are tightened completely.

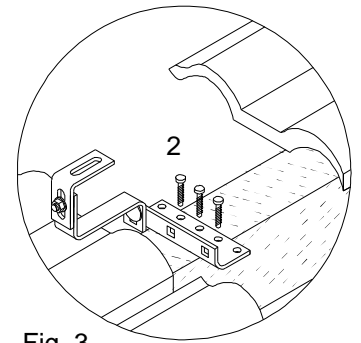

Fig. 3

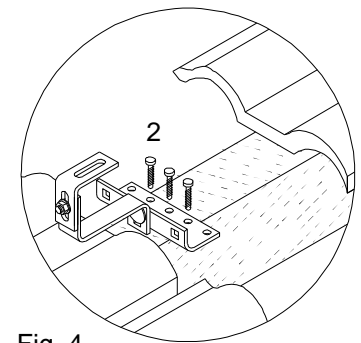

Fig. 4

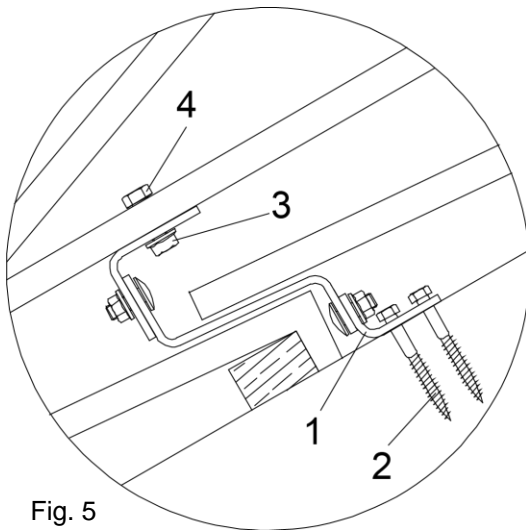

Fig. 5

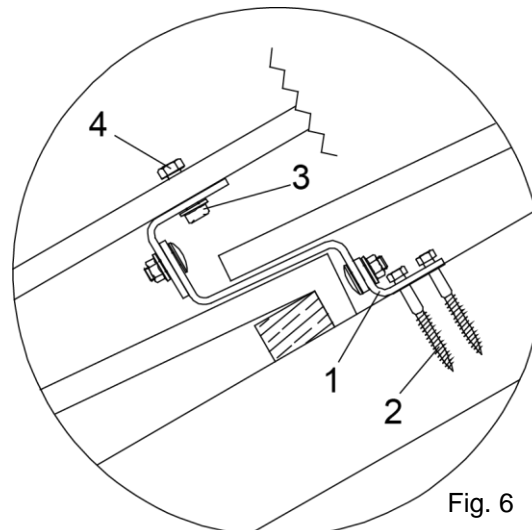

Fig. 6

ATTENTION!

All bolts and nuts for weight-bearing connections have to be tightened with a calibrated torque handle. The torque table can be found in the „Safety and installation manual for flat plate collectors“.