

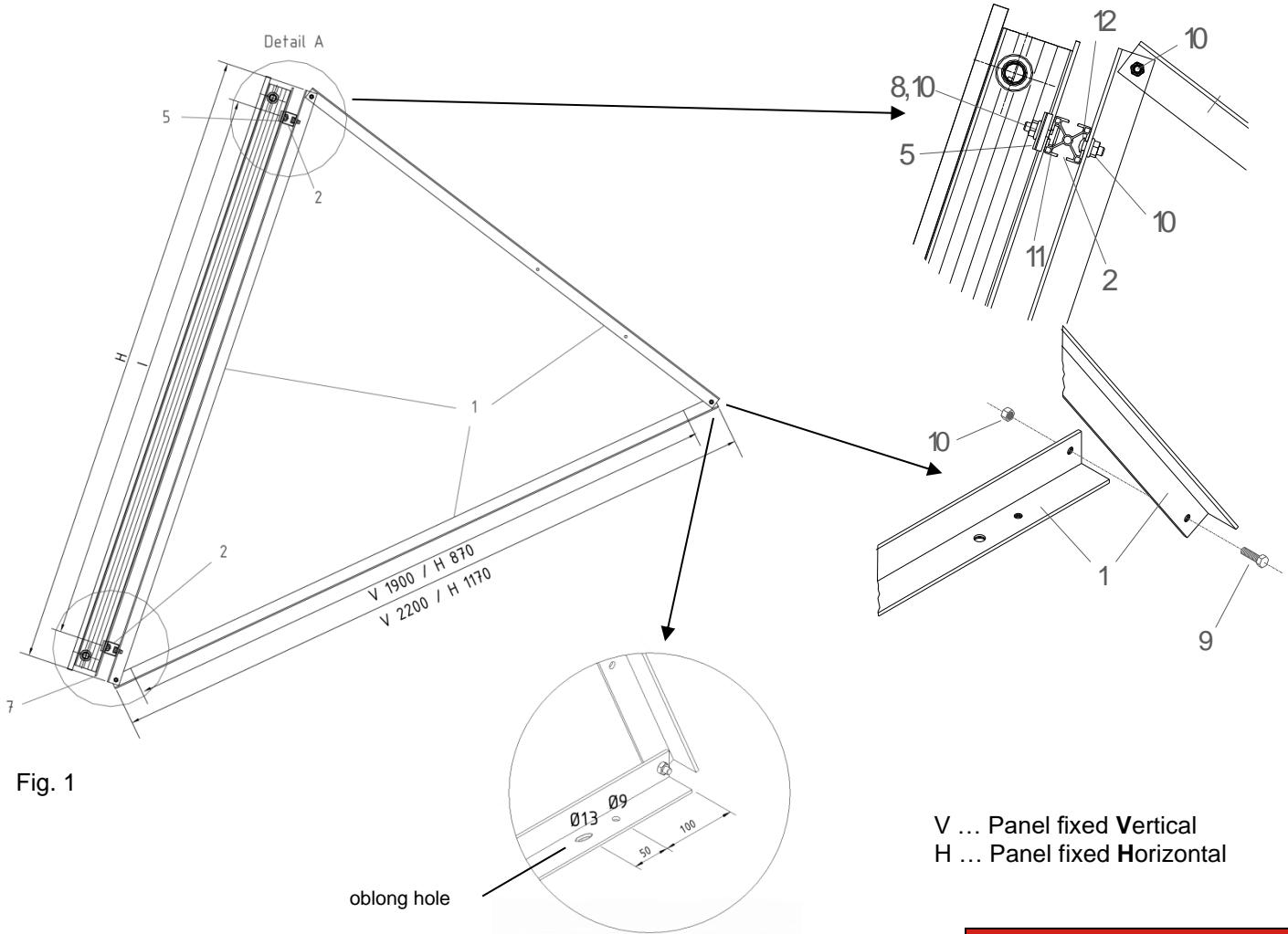

Installation rack for sunWin 24

Installation rack for sunWin 24



V ... Panel fixed Vertical
H ... Panel fixed Horizontal

Pos.	Designation	Fixing rows (triangle)	
		2	3
1	Installation rack Alu 40 x 40 x 4 mm (basic-, supporting-, diagonal part)	2	3
3	Alu strut (natural), l: 2280 mm	2	2
6, 9	Screw M8 x 20 mm_V2A	10	12
10	Nut SS M8_V2A	14	18
12	Carriage bolt M8 x 20 mm_V2A	4	6
Required accessories		Number of panels	
2	Mounting rail (horizontal) Alu 35 x 35 mm	2	3
4	Connection piece	depending on panel / installation type	
5	Mounting clamp		
7	Slide-protection	3 (*)	4 (*)
8,11	Hammerhead-bolt M8x25 mm_V2A	depending on panel / installation type	
10	Nut SS M8_V2A		
Mounting clamps			
5a	sunWin 24 ... horizontal	1000235702	
5b	sunWin 24 ... vertical small	1000235702	
	sunWin 24 ... vertical wide	1000230261	

(*) in case of horizontally assembling use 1 pc. slide-protection additionally each



Installation rack for sunWin 24

1. Fix the installation racks (1) using the screws (9) as well as the nuts (10) like in the figure (Fig. 2) below illustrated.

Possibility only with installation rack in 45 degree design:

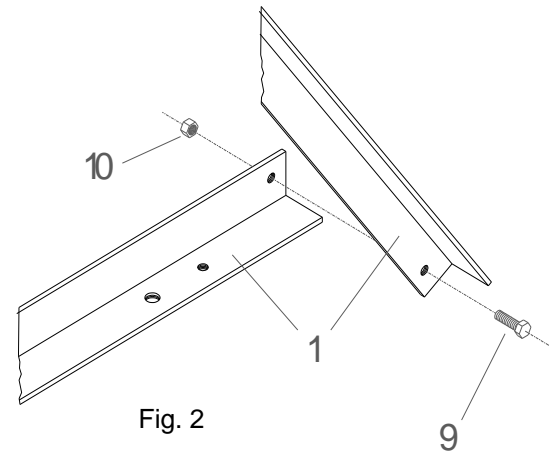
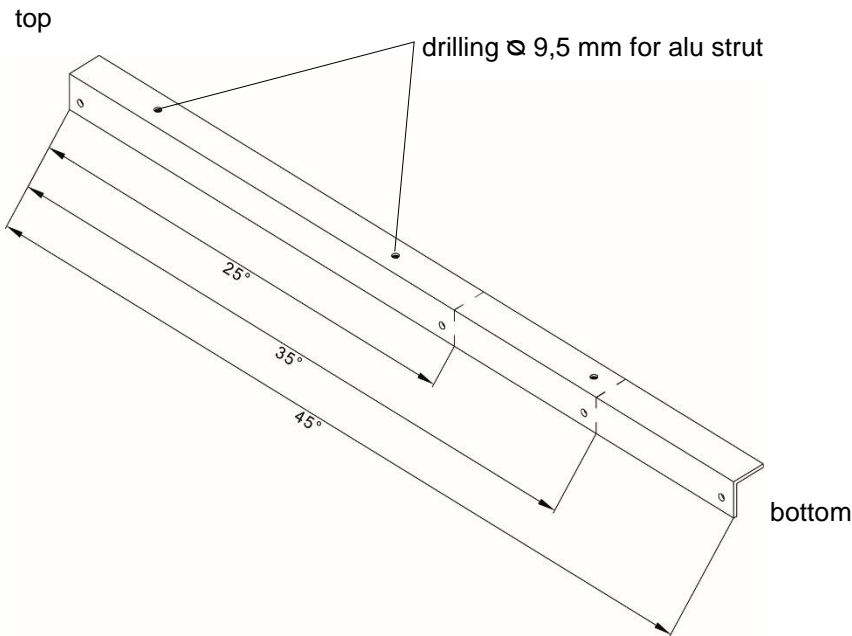

The rear part of the installation rack (see Fig. above) is dimensioned for achieving a maximum inclination of 45°. For achieving the inclinations 35° or 25° the profile can be cut off according to the length table given below.

Lenght table in mm (guidlines)			
Angle	VERTICAL Typ 24	HORIZONTAL Typ 24	
25°	969 mm	523 mm	
30° (optional)	1153 mm	620 mm	
35°	1335 mm	716 mm	
40° (optional)	1508 mm	810 mm	
45°	1691 mm	903 mm	

2. Determine the position of the installation racks (1) on the roof – considering the measurement distances (W) given on the table on the last two pages (**data serve as guidelines, depending on the installation type**). Fix the installation racks using one of the mounting sets (accessories available), or other adequate material on the ground.
3. Install the alu struts (3) using the screws (6) and the nuts (10) in the corresponding drilling on the installation rack (1) as illustrated in Fig. 4 on next page. The required drillings on the alu strut have to be made on site. The first alu strut must be positioned between the lower drilling of the first triangle (1) and the upper drilling of the second triangle. The second alu strut is positioned from top to bottom (see Fig. 3).

Fig. 3: Example with 6 fixing rows (supporting frames) and alu struts



Installation rack for sunWin 24

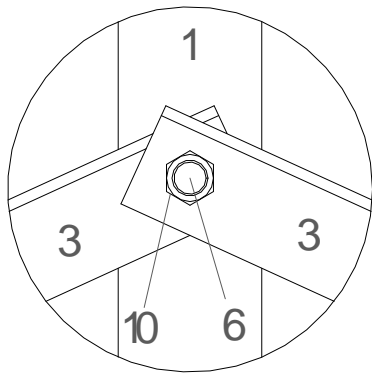

Fig. 4

Detail A

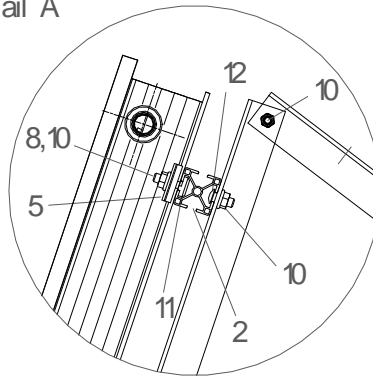

Fig. 5

4. Fix the mounting rail (2) on top and bottom (compare Fig. 1) using the clamps (5), the carriage-bolts (12) and the nuts (10) on the diagonal part of the installation racks (see Fig. 5).

5. Installation of the panels:

Put the slide-protection (7) into the mounting rail at the bottom (2) (Fig. 7). In the next step put the panels on the construction. The panel frame fits closely to the slide-protection. Fix the panels with the clamps (5) by means of hammerhead-screw (8) and nuts (10) at the mounting rail sideways 2 times on top and bottom.

connection-set for rail

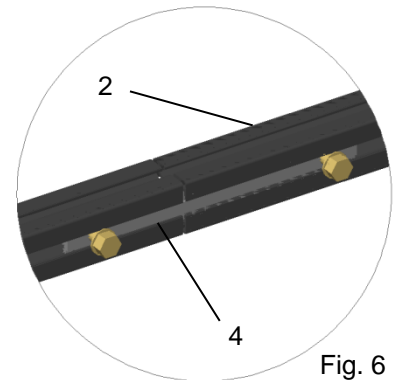

Fig. 6

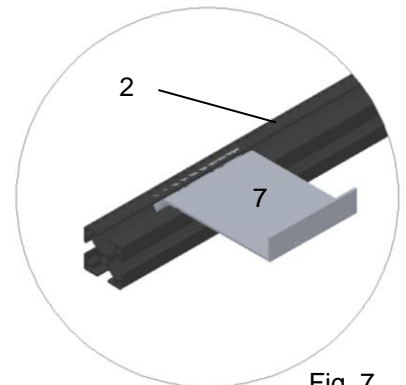
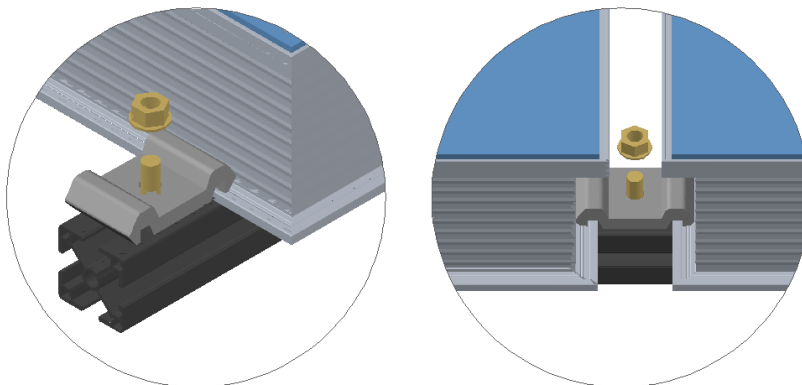

Fig. 7

The mounting clamps (5) have to be placed according to the panel type as follows:

a.) sunWin 24 ... horizontal



Installation rack for sunWin 24

b.) sunWin 24 ... vertical

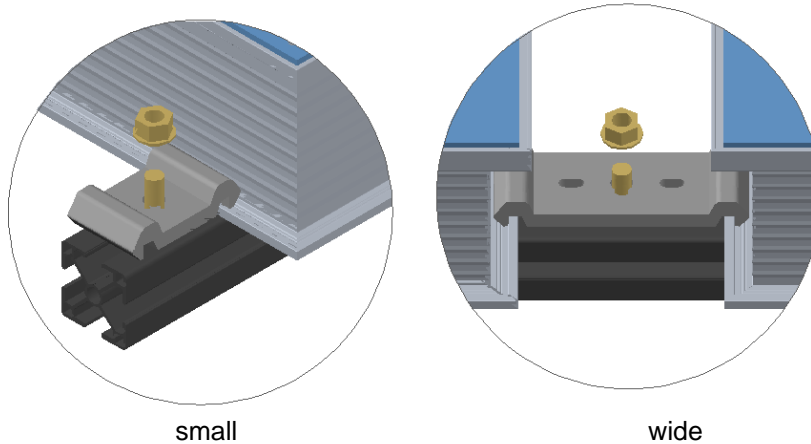

The hydraulic connection between each panel is made by a clamp ring screwing (as a Set, accessories). First, tighten them using 2 open-ended spanner to obtain the proper distance between the panels.

NOTE! Before screwing of the compounds have the treads and the sealing surface are greased (e.g. silicone milk). It's necessary to pull against while screwing otherwise the collecting pipe could be rotated !!!

recommended interconnection-schemes:

sunWin 24 vertikal →
forerun (sensor) right

Vertikal Serie → Vorlauf rechts

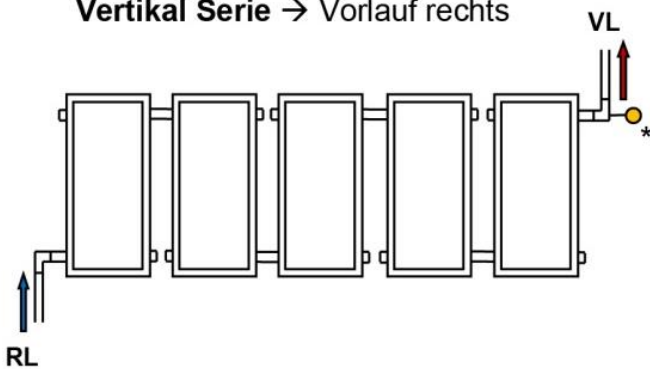

sunWin 24 horizontal →
forerun (sensor) right

horizontal Serie → Vorlauf rechts

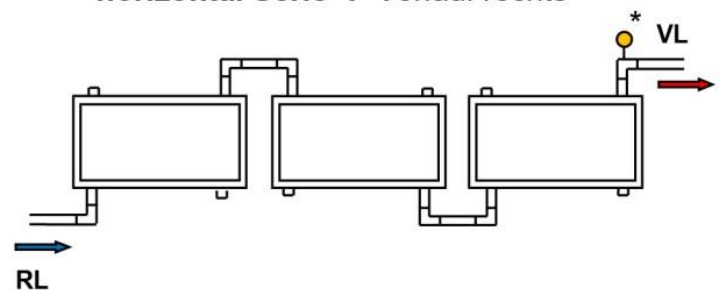

6. Check finally that the clamps (5) and screws (6), (8), (9) and (12) are fastened accurately on the construction as in the Figure nearby illustrated.

ATTENTION!

All bolts and nuts for weight-bearing connections have to be tightened with a calibrated torque handle. The torque table can be found in the „Safety and installation manual for flat plate collectors“.

Detail A

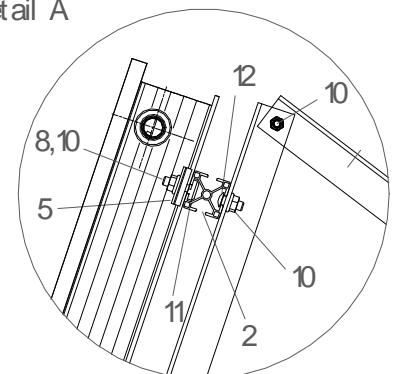

Installation rack for sunWin 24 & sunWin 24M

Measurement and weight												
Type vertical												
Number of panels sunWin 24 / 24M	1	2	3	4	5	6	7	8	9	10	11	12
Installation racks (triangles)	2	3	4	5	6	7	8	9	10	11	12	13
H (mm) panel	2064											
GL (mm) *	1154	2378	3602	4826	6050	7274	8498	9722	10946	12170	13394	14618
W (mm)	800	839	967	1031	1070	1095	1114	1127	1138	1147	1154	1160
I (mm) → see Fig. 1	1850											
* ... without overhang	weight per Fixing row (triangle) appr. 8,5 kg											
Type horizontal												
Number of panels sunWin 24 / 24M	1	2	3	4	5	6	7	8	9	10	11	12
Installation racks (triangles)	2	3	4	5	6	7	8	9	10	11	12	13
H (mm) panel	1154											
GL (mm) *	2064	4146	6228	8310	10392	12474	14556	16638	18720	20802	22884	24966
W (mm)	1600	1723	1843	1902	1938	1962	1979	1992	2002	2010	2016	2022
I (mm) → see Fig. 1	930											
* ... without overhang	weight per Fixing row (triangle) appr. 7 kg											

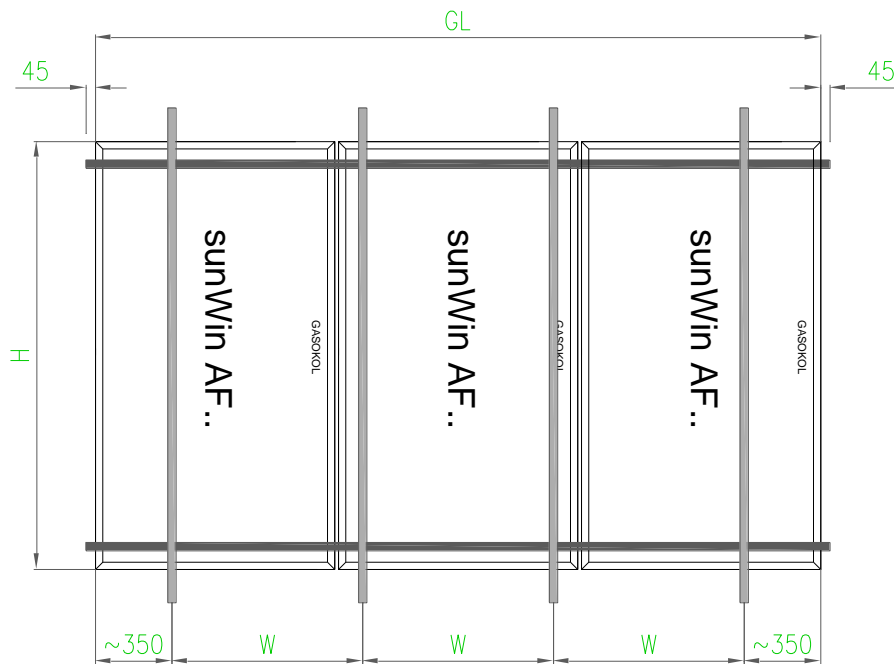

Figure – Installation design, 3 panels in a row